

*“Never, in this world of human conflict,
have so many been indebted to so few
for so much.”*

These words were delivered by Winston Churchill when he was Prime Minister of Britain, in praise of the Royal Air Force during the early days of the World War II. Today, they could be easily attributed to NPSH and Cavitation. Engineers all over the world are indebted to a very tiny percentage of the operating family of pumps for an over-abundance of analysis, discussion and confusion.

More paragraphs have been penned on this topic than on every other aspect of pumping combined, yet the vast majority of the world’s pumps have never experienced the problem because those involved followed one simple rule.

**To avoid Cavitation,
NPSH Available > NPSH Required**

For well over 20 years every reputable Pump Manufacturer has conformed to a single testing standard to establish the NPSH required by a pump. That standard identifies the value of the Net Positive Suction Head required by the pump based on a 3% head drop. In other words it is that amount supplied to a pump which creates a reduction in the total head of no more than 3%.

Some specialty pumps in extremely critical applications are sometimes required to identify the NPSH required for a 1.0% head drop, or occasionally at the Incipient Cavitation point. It must be stressed that these are not the standard “off-the-shelf” pump styles that are used by the vast majority of industry.

These are special pumps only. All pump manufacturers design their standard pump range to operate with an NPSH value tested at a 3% head drop.

NET POSITIVE SUCTION HEAD

by *Ross Mackay*

Consequently, every major pump manufacturer can tell you the NPSH required by their pump when operating at a particular Head-Capacity condition. When exactly that amount is supplied, the pump will be cavitating, but at such a low level of energy that the resulting symptoms (i.e. noise, vibration and impeller damage) will be difficult to detect, and the long term detriment to the operation of the pump will be minimal.

So Let’s Get Practical..... Before you start getting involved in detailed analysis and discussion of your cavitation problem, make sure you are first following the basic rules of engagement.

To avoid cavitation in the vast majority of cases, the NPSH Available from the system must be greater than the NPSH required by the pump. Usually a few feet of a difference will be sufficient.

NPSHA > NPSHR

The NPSHR is a function of the pump design, and changing it should involve the pump design engineers.

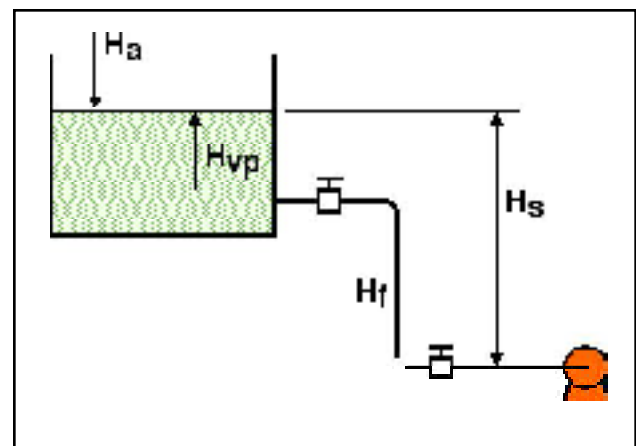

The NPSHA is a function of the system design involving only four factors, all of which are in the control of the plant personnel.

$$\text{NPSHA} = H_s + H_a - H_{vp} - H_f$$

where:

H_s = the static head above the centerline of the impeller,

H_a = the pressure on the free surface of the liquid in the suction tank,

H_{vp} = the vapor pressure of the liquid, and

H_f = all the friction losses on the pump inlet side.

It is therefore apparent that, if a pump is cavitating, we should strive to increase the first two factors in the equation, and/or decrease the second two factors.

Let's consider these factors as they relate to a typical pump inlet system as shown in Fig. 1.

Static Head (H_s)

To increase the static head available to the pump is a simple (?) matter of lowering the pump, or raising the suction tank, or the level in the tank. The physical movement of the tank or pump would usually be a costly proposition, yet the raising of the tank levels may be relatively cheap and simple, and can frequently cure the problem.

Surface Pressure (H_a)

The surface pressure can be a little tricky to change if the suction source is the Atlantic Ocean or some other body of water that resists control by mere mortals. It might be possible however to enclose a man-made tank and pressurize it, or even introduce a nitrogen blanket. Both of these possibilities are subject to the dictates of the operating system. For example, increasing the pressure inside a deaerator would defeat the whole function of that vessel and must therefore be considered impractical. However, as pressure is one of only four factors in NPSHA formula, it is worthy of some consideration in certain installations.

Vapor Head (H_{vp})

The only way to reduce the vapor pressure of a liquid is to reduce its temperature. Under many operational conditions this will be unacceptable and can be ignored. Also, the extent of the temperature change needed to provide an appreciable difference in NPSHA will render this method inappropriate.

Friction Losses (H_f)

As pump inlet piping is notoriously bad in the vast majority of installations throughout the world, this is the area where significant improvements can often be realized. However, I must caution you against the tendency to shorten the length of suction piping simply to reduce friction losses. While this will be effective, it could deny the liquid the opportunity of a smooth flow path to the eye of the impeller. This, in turn, could cause turbulence and result in air entrainment difficulties that create the same symptoms as cavitation. To avoid this, the pump should be provided with a straight run of suction line in a length equivalent to 5 - 10 times the diameter of the pipe. The smaller multiplier should be used on the larger pipe diameters and vice versa.

The most effective way of reducing the friction losses on the suction side is to increase the size of the line. For example, friction losses can be reduced by more than 50% by replacing a 12 inch line with a 14 inch line. Exchanging a 6 inch line for an 8 inch line can reduce the friction losses by as much as 75%. Reduction in friction losses can be achieved even with the same line size by incorporating long sweep elbows, changing valve types and reducing their number. Be careful of Suction Strainers that are left over from the commissioning stage of a new plant. The blockage in the strainer basket steadily raises the friction loss to an unacceptable level. To avoid this problem, a strainer can be frequently located downstream of the pump and the pump selected to handle the solid sizes expected.

The Most Practical Cure

The most effective cure for cavitation is the one that is the most practically viable within the limitations of sound economical principles. Do not automatically dismiss any possible option just because it may cost “a lot of money”. The long term evaluation will frequently prove beneficial.

The Simple Cure

From my experience in plants all over the United States and in many other countries around the world, it has become evident that many pumps are cavitating for the want of one or two feet of NPSH. As a result of this, I have found that the relatively simple change of raising the level of the liquid at the suction source to be an extremely simple and practical cure. Again, it is a little difficult if the suction source happens to be the Atlantic Ocean, but it is frequently possible, practical and effective.

Conclusion

In this world of “NPSH conflict”, I would stress that, before you start getting involved in detailed analysis and discussion of your cavitation problem, ask yourself two questions:

First of all, is this really cavitation I am dealing with, or is it air entrainment or recirculation? If it isn't Cavitation, no amount of adjustment of NPSH will be effective.

Secondly, am I providing enough NPSH to the pump?

If you can say ‘yes’ to both these questions, the likelihood is that your cavitation will disappear. If it doesn't, you have one of these very special and important cases that are being discussed in the other articles in this issue of Pumps and Systems.

Ross Mackay specializes in helping companies reduce pump operating and maintenance costs by conducting training courses in person, and through a self-directed video program.

Ross Mackay Associates Ltd.

P.O. Box 670-PMB-29, Lewiston, NY, 14092
4 Simmons Crescent, Aurora, ON, Canada L4G 6B4

Tel: 1-800-465-6260 Fax: 1-905-726-2420

Email: ross@rossmackay.com

Web Site: www.rossmackay.com